



SMART VENT® - Model: 1540-510



Dual Function SMART VENT® **Superior Flood Protection and Natural Air Ventilation**

ICC-ES Evaluated and FEMA Accepted Foundation Flood Vents

- Potential savings on homeowner's NFIP premiums
- Preserves aesthetic beauty of a home by requiring 2/3 less vents
- Each vent certified to protect 200 sq. ft. of your home
- Code Compliant, FEMA accepted, ICC-ES Evaluated
- All Stainless Steel construction meets or exceeds flood and corrosion resistance code requirements
- Patented automatic floats release bi-directional flood door
- Temperature controlled louvers automatically open in warm weather and close in cold weather

One 16" x 8" vent is certified to cover 200 square feet of enclosed area for flood protection and 51 square inches for ventilation

SMART VENT® models are certified to provide flood protection and ventilation. This model is used for a home with a crawl space or any enclosed area that desires natural air ventilation and flood protection. All stainless steel construction resists weather and pest.



SMART VENT

www.smartvent.com • 877-441-8368



SMART VENT® - Model: 1540-510



Model #: 1540-510

Installation Type: Masonry Wall

Style: louvered

Dimensions: 16" x 8"

Rough Opening: 16¼" x 8¼" (one block, or CMU)

Finish: Stainless Steel (Standard)

Available Powder Coat Colors For Special Order:



White



Wheat



Gray



Black



Stainless (standard)

Optional Accessories:

Fire Damper, Interior Trim Flange & Inner Sleeve, Rain Shield

Other Models Available: Insulated FLOOD VENT, Overhead Garage Door Model, Stacked and Quad Configurations, Models for Wood Studded Wall Applications and Pour in Place Buck Systems.

There's more online at www.smartvent.com

Dealer Locator, Installer Locator, Cad Drawings, Installation Instructions, Technical Specifications, Frequently Asked Questions, Videos, Testimonials, Resource Library Database, Insurance Forms.



Rapidly rising floodwater can put extreme pressure on the foundation walls causing improperly vented structures to buckle and collapse. SMART VENTS® quickly and efficiently equalize the pressure and minimize damage.

How it works:

Flood Protection: The SMART VENT® door is latched closed until flood water enters. Entering flood water lifts the patented internal floats which unlatches and rotates the door open. This allows the flood water to automatically enter and exit through the frame opening, relieving the pressure from your foundation walls.

Ventilation: A bimetal coil (like a thermostat, no electricity is needed) automatically opens and closes the ventilation louvers as temperature changes. They will be closed when it is freezing outside and open when it is warm outside to provide natural ventilation.

Important note: SMART VENT® does not rely on the louvers to let floodwater in and out. Regardless of the louvers' position, opened or closed, when floodwater flows into the door, the internal floats release the door to rotate open to relieve the hydrostatic pressure. The louvers and pest screen are rotated out of the path of the floodwater. The temperature-controlled louvers are for ventilation purposes only.

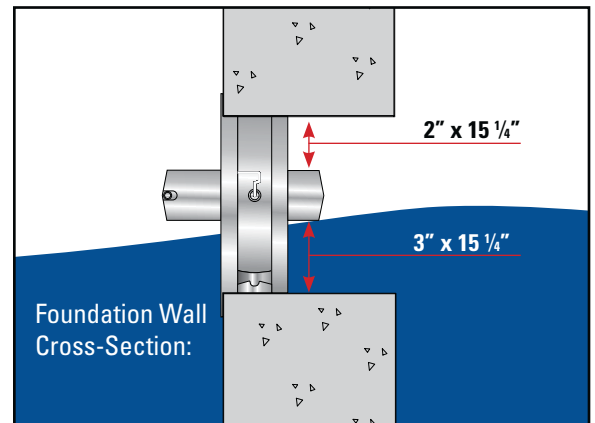

How does one SMART VENT® provide so much coverage?

You may have heard that FEMA requires that flood openings provide one square inch of opening per one square foot of enclosed area, referring to dimensions of the opening in proportion to the space to be vented. This is only partially correct. FEMA's regulations and guidelines do state that a non-engineered flood vent solution must (among other requirements) provide one square inch of opening per square foot of enclosed area to be vented. However; all SMART VENT® products are ICC-ES certified engineered openings. They have been designed, engineered, tested, rated, and certified to provide flood relief so efficiently that only one unit is needed for 200 square feet of enclosed area. It would be our pleasure to contact your code official, surveyor, or insurance agent if they require more information.